

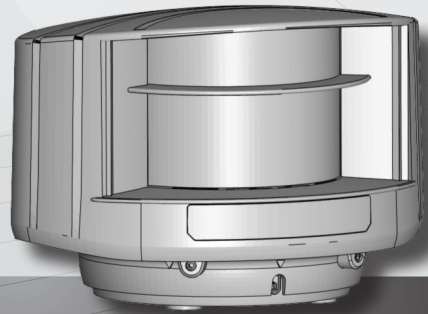

EN



## LZR<sup>®</sup>-s600

LASER SCANNER  
FOR BUILDING AUTOMATION AND SECURITY  
(US version)



User's Guide

## BUILDING AUTOMATION AND SECURITY

Other use of the device is outside the permitted purpose and can not be guaranteed by the manufacturer.  
The manufacturer cannot be held responsible for incorrect installations or inappropriate adjustments of the sensor.

## DESCRIPTION

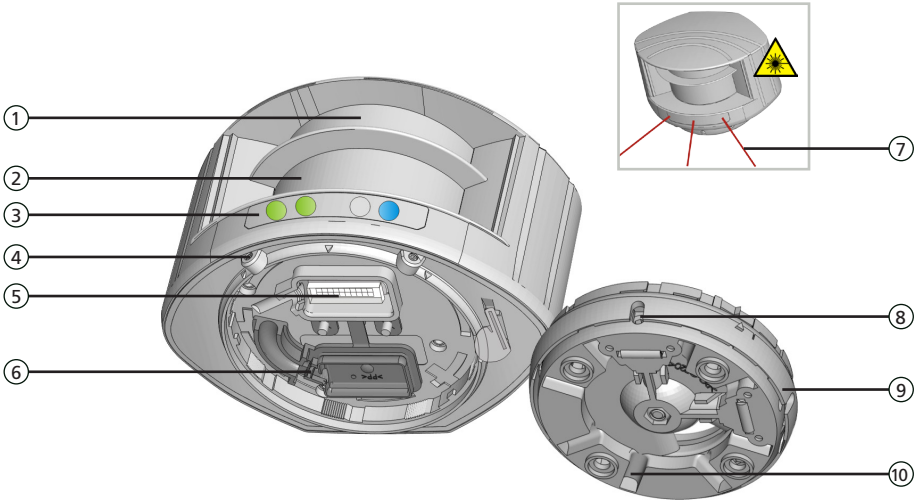

- |                                |  |
|--------------------------------|--|
| 1. laser sweep emission        | 6. protection cover                    |
| 2. laser sweep reception       | 7. visible laser beam (3)              |
| 3. LED-signal (4)              | 8. notch for tilt angle adjustment (2) |
| 4. screw for position lock (2) | 9. adjustable bracket                  |
| 5. connector                   | 10. cable conduit (4)                  |

## LED-SIGNAL

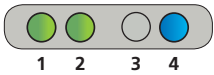

1. Detection LED: relay 1 – field 1
2. Detection LED: relay 2 – field 2
3. Error LED
4. Power LED

### DETECTION LEDS

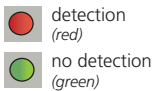

### ERROR LED



### POWER LED

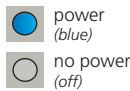

LED flashes quickly



LED flashes



LED flashes slowly



LED is off

**TIP!** All LEDs can be switched off and on again by remote control:



## SYMBOLS



Caution!  
Laser radiation



Remote control  
sequence



Possible  
remote control  
adjustments



Factory values



Alarm

## SAFETY

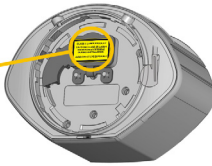

The device contains IR and visible laser diodes.  
IR laser: wavelength 905nm; max. output pulse power 75W (Class 1 according to IEC 60825-1)  
Visible laser: wavelength 650nm; max. output CW power 3mW (Class 3R according to IEC 60825-1)

The visible laser beams are inactive during normal operation. The installer can activate the visible lasers if needed.



### CAUTION!

Use of controls, adjustments or performance of procedures other than those specified herein may result in hazardous radiation exposure.

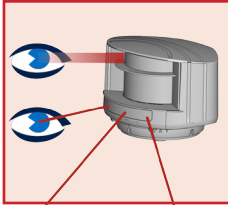

Do not look into the laser emitter or the visible red laser beams.

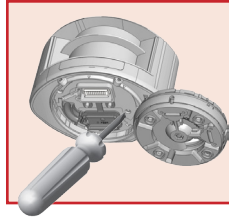

The warranty is void if unauthorized repairs are made or attempted by unauthorized personnel.



Only trained and qualified personnel may install and adjust the sensor.

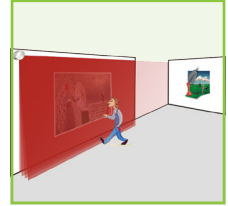

Test the proper operation of the installation before leaving the premises.

## INSTALLATION AND MAINTENANCE

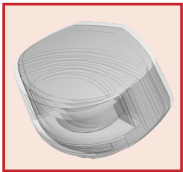

Avoid extreme vibrations.

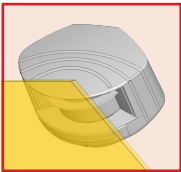

Do not cover the front screens.

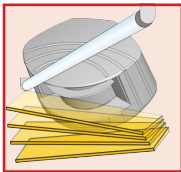

Avoid moving objects and light sources in the detection field.

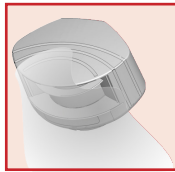

Avoid the presence of smoke and fog in the detection field.

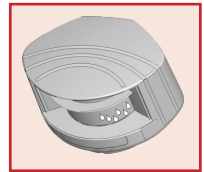

Avoid condensation.

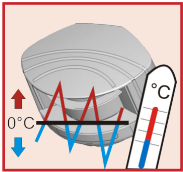

Avoid exposure to sudden and extreme temperature changes.

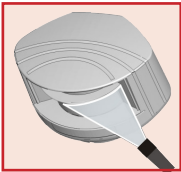

Avoid direct exposure to high pressure cleaning.



Do not use aggressive products to clean the front screens.

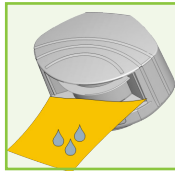

Wipe the front screens regularly with a clean and damp cloth.

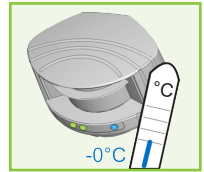

Keep the sensor permanently powered in environments where the temperature can descend below 32°F.

PROTECTION OF WORKS OF ART: WARNING & ALARM

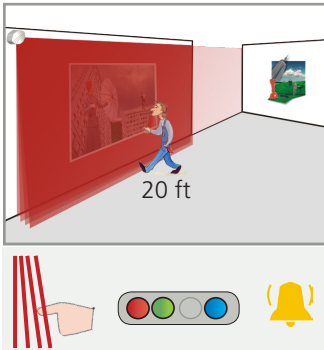

Field 1 (4 active curtains) triggers relay 1:  
**WARNING**

Adapt the field widths (20 ft for example):

Reduce field 2 to 1 curtain (C1):

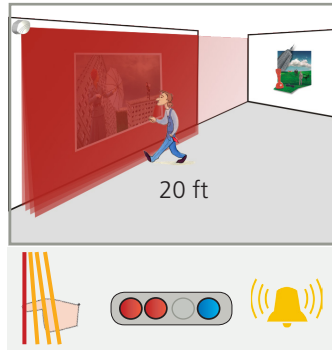

Field 2 (only curtain C1 active) triggers relay 2:  
**ALARM**

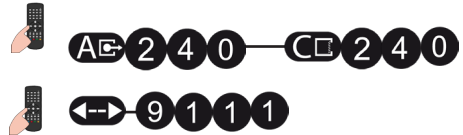

DAY AND NIGHT FEATURE

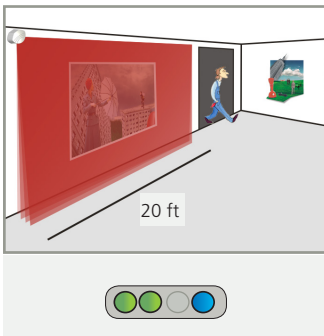

During day time, only field 1 is active and triggers relay 1.

Adapt the field width of field 1 (20 ft for example):



Adapt the field width of field 2 (25 ft for example):

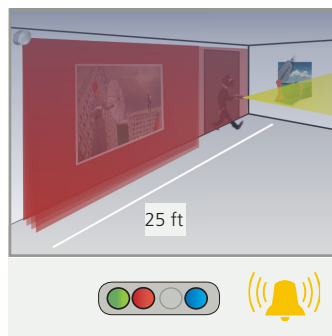

During night time field 2 is active too and triggers relay 2: intrusion alarm

# 1 MOUNTING

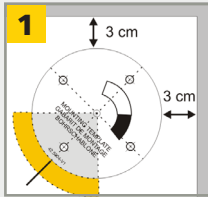

Use the adhesive mounting template to position the sensor correctly.

The grey area indicates the detection range.

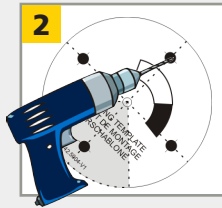

Drill 4 holes as indicated on the mounting template.

Drill a hole (1/2 in min.) for the cable if possible.

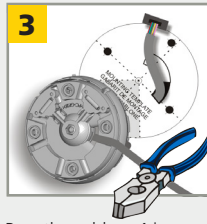

Pass the cable  $\pm 4$  in through the cable opening.

If drilling an opening is not possible, use the cable conduits on the back side of the bracket.

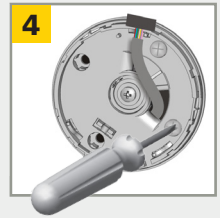

Position the bracket and fasten the 4 screws firmly in order to avoid vibrations.



Open the protection cover, plug the connector and position the cable in the channel.



Close the protection cover and fasten it firmly.

**NOTE:** FACTORY WARRANTY VOIDED IF PROTECTION COVER IS NOT USED!

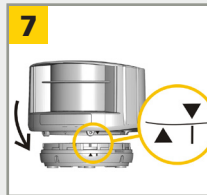

Position the housing on the bracket.

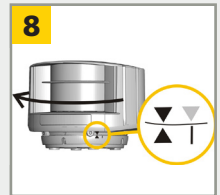

Turn the sensor until the two triangles are face to face.

# 2 WIRING

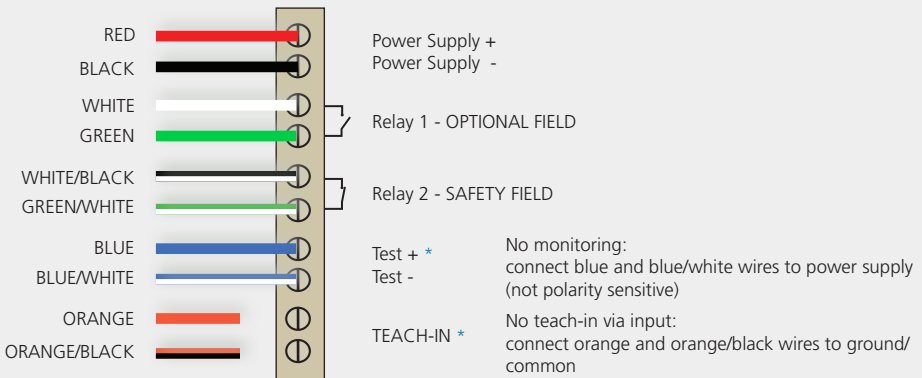

\* SEE APPLICATION NOTES OR CONTACT BEA FOR TECHNICAL SUPPORT

### 3 POSITIONING



Unlock the sensor and activate the visible laser beams.

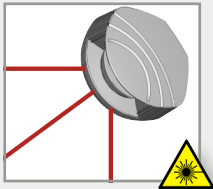

The visible laser beams indicate the approximate position of curtain C1 and the angle of the detection field.

The visible laser beams will remain active for 15 minutes or can be turned off the same way they were activated.

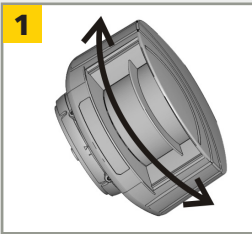
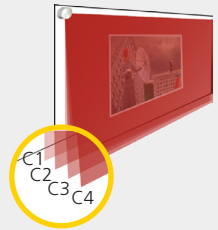

Adjust the **lateral position** of the detection field.

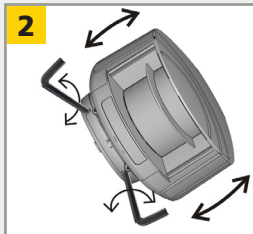

Adjust the **tilt angle** of the detection field with the 3 mm hex key.

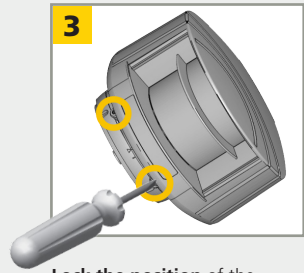

**Lock the position** of the mounting bracket to avoid malfunctioning in case of extreme vibrations.

### 4 MOUNTING SIDE

Select the corresponding mounting side.

The sensor learns its environment and automatically determines the detection field(s). Both red LEDs flash slowly and the 3 visible laser beams automatically light up for 30 seconds.

Stay outside of the detection zone to avoid disturbances.



1

2

3

4

5

left

right

left

right

center

WITH BACKGROUND

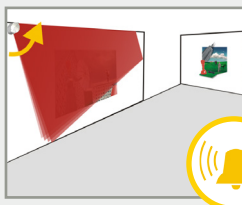

The sensor memorizes the floor as reference point and signals a fault when its orientation is changed.

WITHOUT BACKGROUND

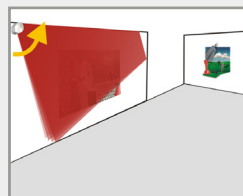

No reference point is memorized, no alarm in case of interference.

## 5 FIELD DIMENSIONS

FIELD 1

WIDTH



**A** 0 2 0 - 9 8 4 0 0 0

20 in - 984 in field 2 = field 1

394 in

HEIGHT



**B** 0 2 0 - 9 8 4 0 0 0

20 in - 984 in no field

394 in

FIELD 2

WIDTH



**C** 0 2 0 - 9 8 4 0 0 0

20 in - 984 in no field

394 in

HEIGHT



**D** 0 0 4 - 9 8 4

4 in - 984 in

394 in

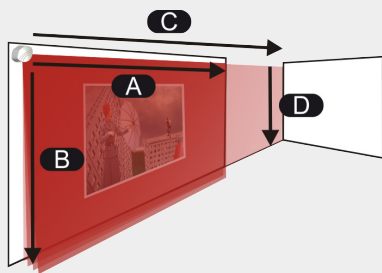

EXAMPLES



**A** 0 6 2 for a field width of 62 in



**B** 0 4 5 for a field height of 45 in

**IMPORTANT:** Test the proper operation of the installation before leaving the premises.

### TEACH-IN

The teach-in can be launched either via remote control or via connecting the orange and orange/black wires together.

Launch a teach-in:

- after changing the sensor position
- when new objects are added to or changed in the detection zone.

During teach-in, the sensor learns its surroundings and adapts the detection zone shape. Objects in the detection field will be cut out.

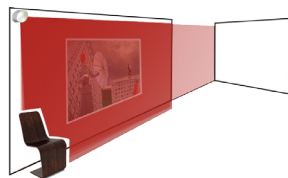

Stay outside of the detection zone to avoid disturbances.

To launch a teach-in via input, please contact SENSORIO for more information.

To launch a teach-in via remote control, use the following sequence:

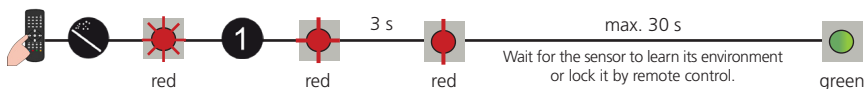

## REMOTE CONTROL ADJUSTMENTS (OPTIONAL)

### DETECTION CURTAINS



CURTAIN C1 C2 C3 C4

- 0 deactivate curtain on both fields
- 1 activate curtain only on field 1
- 2 activate curtain only on field 2
- 9 activate curtain on both fields

EX:

C1 + C2 active on field 1 only  
C3 + C4 active on field 2 only

C1 active on both fields  
C2+C3 active on field 2 only  
C4 deactivated

All curtains active on both fields

C1  
C2  
C3  
C4

The distances between the curtains depend on the mounting height and side. When mounted on the left, the distance between the first and the last curtain is approximately 0.3 ft for every foot (mounting height).

**Example:** at 10 ft the distance is 1.5 ft.

### UNCOVERED ZONE

F2	0	1	2	3	4
	2	4	6	8	10
					in

### IMMUNITY FILTER

	1	2	3	4	5	6	7	8
	indoor	outdoor low	outdoor med	outdoor high	indoor	outdoor low	outdoor med	outdoor high

Increased immunity to rain, snow, fog...

Increased sensitivity  
(detection of black objects, ...)

### MIN. OBJECT SIZE

approximate values

	0	1	2	3	4
	off	2	4	8	16
					in

### OUTPUT ACTIVATION DELAY

approximate values

	0	1	2	3	4	5	6	7	8	9
	off	100	200	300	400	500	600	700	800	900

The outputs are triggered after a constant detection time of x ms (ex. value 3= 300 ms).

### DETECTION FIELD REDIRECTION

F1	0	1
R1	field 1	field 1 or field 2
R2	field 2	field 2

### OUTPUT CONFIGURATION \*



R1 R2

	1	2	3	4
R1	A - NO	P - NC	P - NC	A - NO
R2	P - NC	A - NO	P - NC	A - NO

A = active  
P = passive

NO = normally open  
NC = normally closed



FACTORY VALUES Rx= RELAY OUTPUT

\* SEE APPLICATION NOTES OR CONTACT BEA FOR TECHNICAL SUPPORT



## HOW TO USE THE REMOTE CONTROL

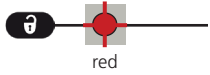

After unlocking, the red LED flashes and the sensor can be adjusted by remote control.



If the red LED flashes quickly after unlocking, you need to enter an access code from 1 to 4 digits.



To end an adjustment session, always lock the sensor.

### ADJUSTING ONE OR MORE PARAMETERS

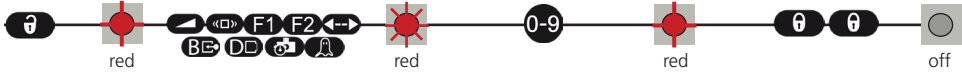

### CHECKING A VALUE



= field width: 132 in (1\_3\_2)  
 green - yellow - green - yellow - green

= field width is defined by teach-in  
 yellow

### RESTORING TO FACTORY VALUES



### SAVING AN ACCESS CODE



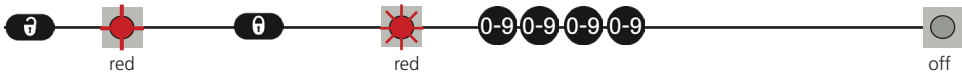



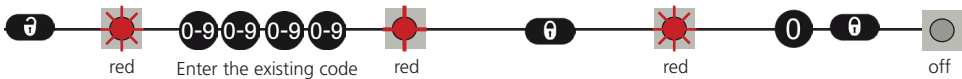

The access code is recommended for sensors installed close to each other.



### DELETING AN ACCESS CODE



X = THE NUMBER OF FLASHES INDICATES THE VALUE OF THE PARAMETER.

	No Blue LED.	<p>There is no power.</p> <p>The polarity of the power supply is inverted.</p> <p>All LEDs have been de-activated by remote control.</p>	<p>1 Check cable and connection.</p> <p>1 Check the polarity of the power supply.</p>
	Only the blue LED is on.	The test input is not connected.	<p>1 Activate the LEDs by remote control.</p> <p>1 Check wiring. The blue and blue/white wires have to be connected to the test input or the power supply.</p>
	The detection LED remains green.	<p>The detection field is too small or deactivated.</p> <p>The object size is too small.</p>	<p>1 Check the size of the fields. 2 Launch a teach-in.</p>
	The Detection LED remains red.	<p>Someone or something is in the detection field.</p> <p>The field is touching the floor, the wall or the door, which leads to detection.</p>	<p>1 Decrease the min. object size.</p> <p>1 Step out of the field and/or remove the any object(s) from the field.</p> <p>1 Activate the 3 red beams and check if the position of the sensor is correct. If not, adjust the hex screws. 2 Verify the field size. 3 Launch a teach-in.</p>
	The orange LED is flashing and the detection LEDs are red.	<p>No background (reference point) is found.</p> <p>The sensor is masked.</p>	<p>1 Check the position of the sensor. 2 Check the mounting side setting. If there is no background, set the mounting side to value 3 to 5. 3 Launch a new teach-in.</p>
	The orange LED is on. Both detection LEDs are orange.	<p>The power supply voltage is exceeding the acceptable limits or is unstable.</p> <p>The sensor exceeds its temperature limits.</p> <p>Internal error</p>	<p>1 Verify and clean the front screens with a clean, damp cloth.</p> <p>1 Check the power supply voltage. 2 Cycle the power.</p> <p>1 Verify the outside temperature where the sensor is installed. If needed, protect the sensor from sunlight using a cover.</p>
	The sensor does not respond to the remote control.	<p>30 minutes after last use of the remote control, the sensor locks the access to the remote control session.</p> <p>The batteries in the remote control are not installed properly or dead.</p> <p>The remote control is poorly oriented.</p> <p>A reflective object is in close proximity to the sensor.</p> <p>Monitoring wires are not connected.</p>	<p>1 Wait a few seconds. If the LED remains ON, cycle the power supply. If the LED turns on again, replace the sensor.</p> <p>1 Cycle the power supply. The remote control session will then be accessible for another 30 minutes.</p> <p>1 Verify or replace the batteries.</p> <p>1 Point the remote control towards the sensor, but with a slight angle. The RC should not be pointed in a right angle in front of the sensor.</p> <p>1 Avoid highly reflective material in proximity to the sensor.</p> <p>1 Connect the blue and blue/white wires to the power supply.</p>
	The sensor does not unlock.	You have to enter a code or the wrong code was entered.	<p>1 Cycle the power. No code is required during the first minute after powering.</p>

## TECHNICAL SPECIFICATIONS

Technology:	Laser scanner, time-of-flight measurement
Detection Mode:	movement and presence
Detection Range:	default: 33 ft x 33 ft @ 2% remission factor max: 82 ft x 82 ft
Angular Resolution:	0.3516°
Min. Detected object size (typ.):	0.8 in @ 10 ft; 1.4 in @ 16 ft; 2.8 in @ 33 ft; 6.9 in @ 82 ft (in proportion to object distance)
Emission Characteristics:	
IR Laser:	wavelength 905 nm; max. output pulse power 75 W (CLASS 1)
Red Visible Laser:	wavelength 650 nm; max. output CW power 3 mW (CLASS 3R)
Supply Voltage:	10-35 V DC @ sensor side
Power Consumption:	< 5 W
Peak Current at Power-on:	1.8 A (max. 80 ms @ 35 V)
Cable Length:	30 ft
Response Time:	typ 20 ms; max. 80 ms (+ output activation delay)
Output:	2 electronic relays (galvanic isolated - polarity free)
Max. Switching Voltage:	35 V DC / 24 V AC
Max. Switching Current:	80 mA (resistive)
Switching Time:	tON=5 ms; tOFF=5 ms
Output Resistance:	typ 30 Ω
Voltage Drop on Output:	< 0.7 V @ 20 mA
Leakage Current:	< 10 μA
Input:	2 optocouplers (galvanic isolated - polarity free)
Max Contact Voltage:	30 V DC (over-voltage protected)
Voltage Threshold:	Log. H: >8 V DC; Log. L: <3 V DC
Response Time Monitoring Input:	< 5 ms
LED Signal:	1 blue LED: power-on status 1 orange LED: error status 2 bi-coloured LEDs: detection/output status (green: no detection; red: detection)
Dimensions (D x W x H):	5.00 in x 3.66 in x 2.75 in (mounting bracket + 0.55 in)
Material:	PC / ASA
Color:	Black
Mounting Angles on Bracket:	-45°, 0°, 45°
Rotation Angles on Bracket:	-5° to +5°
Tilt Angles on Bracket:	-3° to +3°
Protection Degree:	NEMA 4 / IP65
Temperature Range:	Powered: -22° F to +140° F; Unpowered: +14° F to +140° F
Humidity:	0-95 % non-condensing
Vibrations:	< 2 G
Pollution on Front Screens:	max. 30%; homogenous
Norm Conformity:	2006/95/EC: LVD; 2002/95/EC: RoHS; 2004/108/EC: EMC EN 60529:2001; IEC 60825-1:2007 Laser Class 1 & 3R; EN 60950-1:2005; EN 61000-6-2:2005 EMC - Industrial level EN 61000-6-3:2006 EMC - Commercial level

Specifications are subject to changes without prior notice.  
All values measured in specific conditions.



BEA hereby declares that the LZR®-1100/-1110 is in conformity with the basic requirements and the other relevant provisions of the directives 2006/95/EC, 2002/95/EC, 2004/108/EC and 2006/42/EC.

Notified Body for EC inspection: 0044 - TÜV NORD CERT GmbH, Langemarckstr. 20, 45141 D-Essen

EC-type examination certificate number: 44 205 11 392410-002

Angleur, May 2011

Jean-Pierre Valkenberg, Authorized representative and responsible for technical documentation

The complete declaration of conformity is available on our website: [www.bea-industrial.be](http://www.bea-industrial.be)

For EC countries: according to the directive 2012/19/EU for Waste Electrical and Electronic Equipment (WEEE)

